

SIDE PLATES FOR USE WITH WHEEL STYLE BRUSHES



Used in pairs.

Diameter	Arbor Hole	Item No.
3-1/2	5/8	75086
3-1/2	1-1/4	75087
4	5/8	75088
4	1-1/4	75089
5-1/2	5/8	75090
5-1/2	1-1/4	75091
5-1/2	1-1/2	75092
9-5/8	1-1/4	75093
9-5/8	2	75094

BRUSH DRIVE ARBORS



For brushes up to 3" in diameter only. Designed for use with a single brush only. Not for use with grinding wheels, abrasive discs, buffs, buffing pads, or other non-brush perishable tools.

Diameter	Overall Length	Shank Dia.	Item No.	Clamshell
1/4	1-1/2	3/16	75007	75386
3/8	1-3/4	1/4	75008	75387
1/2	1-3/4	1/4	75009	75388
5/8	1-3/4	1/4	75010	75389

CNC ADAPTERS FOR ATB BRUSHES

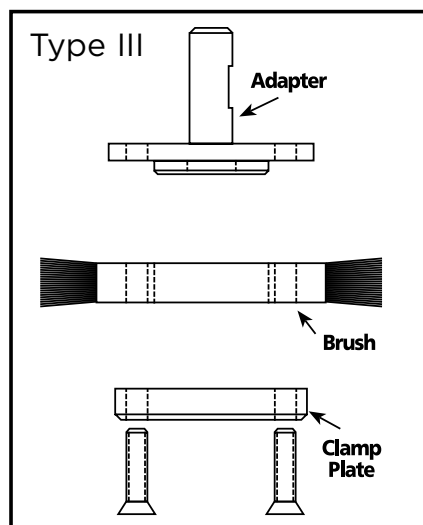
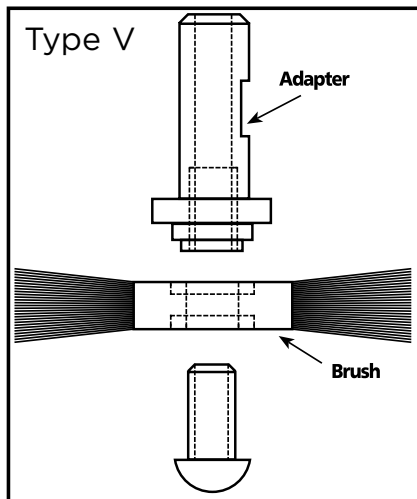

Type III brushes include adapter and clamp plate

Brush Dia.	Arbor Hole	Shank Dia.	Description	Adapter Item No.
3	5/8	3/4	Type V	75117
4	5/8	3/4	Type V	75118
6	2	3/4	Type III	75077
8	2	3/4	Type III	75077
9	2	3/4	Type III	75077
10	2	1-1/4	Type III	75080
12	2	1-1/4	Type III	75080
14	2	1-1/4	Type III	75080